

Fleet: Light Maintenance

Illuminating safety:

The importance of lights, reflectors, and conspicuity for vehicles

Lights, reflectors, and conspicuity: Working lights and reflectors on a vehicle are not only crucial for legal compliance, but they also help with visibility, safety, signaling intentions, and emergency situations. Before operating the vehicle for the day, check for any non-operating lights. At the end of the day, during your post-trip inspection, ensure that you produce a Driver Vehicle Inspection Report (DVIR) for any necessary repairs.

Checking lights: Do not operate if the vehicle has non-working lights in the following categories:

- Headlights
- Lamps on the rear
- Stop Lamps
- Turning signals



In addition to the above listed lights, make sure you check:

- Clearance lights
- Side lights
- Convenience lights

LED lights come with a certain number of light diodes, allowing the light to continue working when a diode fails. The light should be replaced when the number of working diodes reach 50% of the total.



Diode failures

While you may not always have time to wash your vehicle, especially during poor weather conditions or busy times, make sure lights, reflectors and conspicuity tape are wiped clean during inspection as they will increase your safety margin. See the difference in the photo below.



Spot wiped clean

Checking reflectors and conspicuity reflective tape

You can check the chart below for placement of both reflectors and conspicuity reflective tape.

- White tape at corners of power unit and trailers (13 and 9 as listed in chart)
- Red/white tape on top of mud flaps of power unit (14 as listed on chart)
- Red/white tape on sides and rear of trailer, covering approximately 50% of the length and width

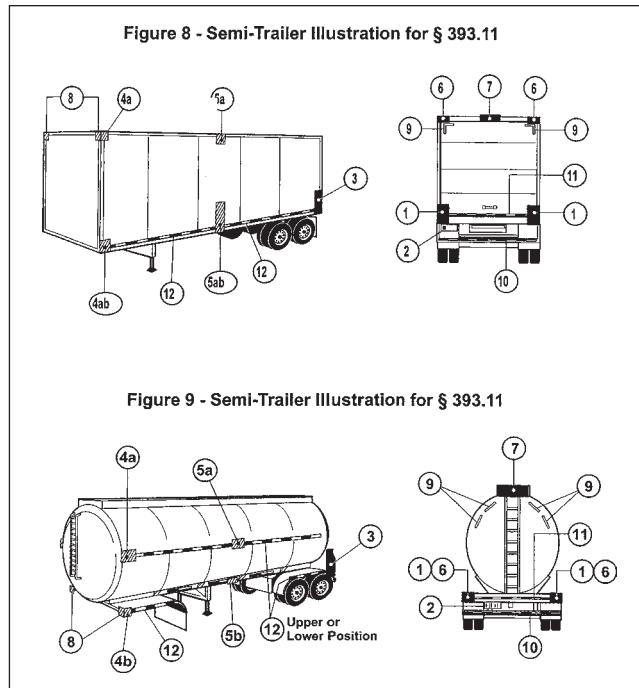
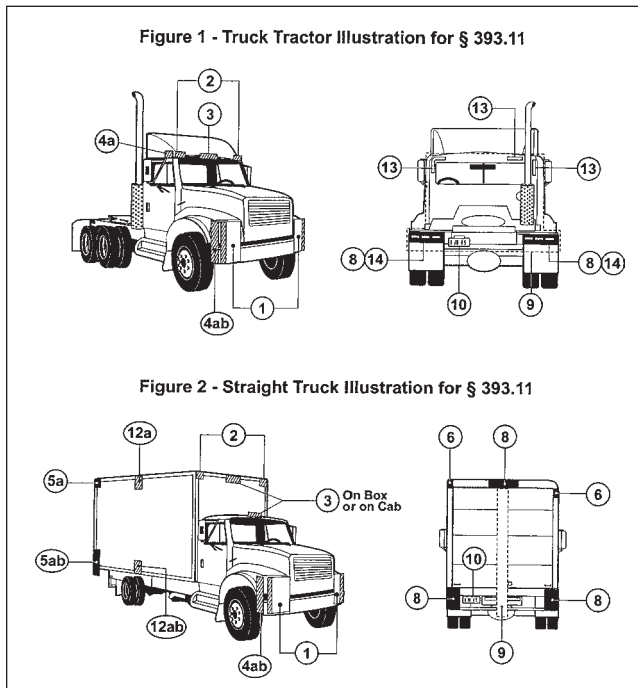

Conspicuity tape: When the reflective tape gets old and brittle, it will flake off, especially during washing with a pressure hose. It will also lose its reflective properties, making it less likely to reflect light and making it less safe.



For further guidance, refer to Federal Motor Carrier Safety Administration 49 CFR Part 393 Subpart B ([ecfr.gov/current/title-49/part-393/subpart-B](https://www.ecfr.gov/current/title-49/part-393/subpart-B)).



For assistance with risk management services or safety resources, contact us at RMSolutions@nationwide.com or 1-800-260-1356.