



Aeration System Design for Cone-Bottom Round Bins

Carol Jones
Extension Agricultural Engineer

Geetika Dilawari
Research Engineer

Before attempting to select, design or manage an aeration system, you should study the following publication: BAE-1101 "Aeration and Cooling of Stored Grain."

Fact Sheet BAE-1101 discusses the importance of choosing the right airflow rate to obtain the desired aeration system capabilities. Power requirements, fan selection, control systems, and management suggestions are also explained.

This fact sheet presents information for the design or selection of aeration system components for cone-bottom round grain bins.

Cone-bottom bins have the advantage of complete and easy unloading. The cone also provides additional storage capacity in the bin.

Below-grade cone-shaped foundations can only be used in areas of low water tables. If the water table rises to the level of the cone, water may enter the cone and cause grain spoilage. Cone-shaped bin foundations are well suited for use in western Oklahoma and should be discouraged in eastern Oklahoma.

When only dry grain will enter the bin, a cone slope of 37° or 3 feet fall in a 4 foot run will allow complete unloading. When wet grain will be handled through the bin, the cone slope should be 45° or 1 foot fall in a run of 1 foot.

Aeration Systems

A typical aeration system for a cone-bottom round grain bin is shown in Figure 1. Round metal ducts are used to distribute air in cone-bottom bins. The upper section of the duct is non-perforated with lower sections perforated. The bottom of the duct is usually open.

If a single duct does not have sufficient surface area to avoid excessive operating pressures, a second fan and duct are added as shown in Figure 1, with air volume divided between the two fans. In large bins, three or more fans and ducts are sometimes required to deliver high airflow rates. In general, centrifugal fans with backward-inclined blades are required to deliver efficient air volumes when operating against the higher static pressures encountered in cone-bottom bins.

Description of Terms

The following terms are used in the design procedure:

fpm = feet per minute, air velocity;

CFM = cubic feet of air per minute, air volume;

CFM/bu = cubic feet of air per minute per bushel, airflow rate

Oklahoma Cooperative Extension Fact Sheets
are also available on our website at:
<http://osufacts.okstate.edu>

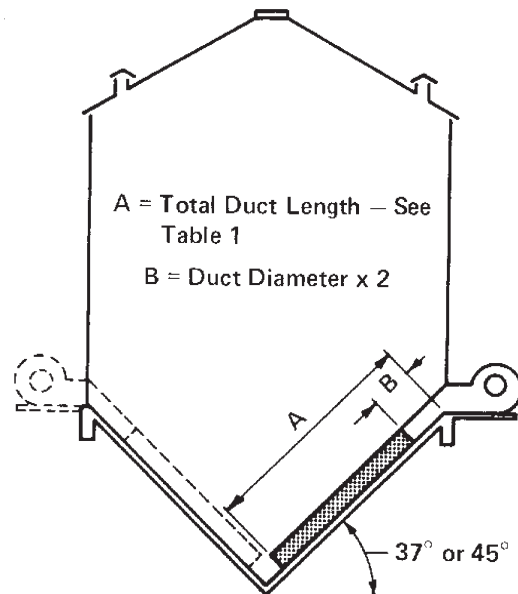

Figure 1. Aeration system for a cone-bottom round grain bin.

Static pressure is the pressure against which the fan must operate, expressed as inches of water.

Design Procedure

The design procedure for aeration systems involves:

1. Determining bin capacity, selecting air-flow rate, and determining total air volume to be delivered;
2. Selecting ducts on the basis of surface area;
3. Determining operating static pressure; and
4. Selecting fans to deliver the required air volume when operating against the expected static pressure.

Determining Bin Capacity and Air-Flow Volume

Bin capacity is the number of bushels which can be stored in the bin plus the number which can be stored in the cone. The capacity of the bin with and without cone can be determined from Table 1. Bin capacity does not include storage in the roof section.

Example: Consider a 30 feet diameter bin with 19 foot sidewalls and a 45° concrete cone shaped foundation. The bin capacity with and without cone can be found using Table 1. In addition to individual capacities Table 1 gives the total capacity, bin plus cone. From Table 1, bin capacity without cone is 10,775 bu. The capacity of a 30-foot diameter, 45° cone is 2,820 bu. Therefore total capacity, bin plus cone, is 13,595 bu. Table 1 can be used for bins with concrete cone shaped foundations and for steel hopper bottom bins.

It is best to aerate the grain with 1/5 cfm/bu (0.2 cfm/bu). The total airflow requirement would be 0.2 cfm/bu multiplied by the total bushels in the bin.

$$0.2 \text{ cfm/bu} \times 13,595 \text{ bu} = 2719 \text{ cfm}$$

Table 2 gives the maximum length of duct which may be placed down one side of the cone foundation for various bin diameters and the two cone slopes.

Example: For a 30 ft. diameter bin with 45° cone shaped bottom, the maximum length of a duct is 20 feet (using Table 2).

As shown in Figure 1, the air makes a turn when it leaves the fan and transition and enters the duct. This air turbulence is accompanied by an increase in static pressure in the initial section of the duct. For this reason, the initial section of the duct should be non-perforated for a distance equal to twice the duct diameter.

Max. length of duct (Table 2) – (2 x the duct diameter) = max. length of perforated duct

Example: If a 12 inch diameter duct is to be used in our example bin (30 ft. diameter bin), the maximum length of perforated duct is 18 ft.

$$12 \text{ inches} = 1 \text{ ft.}$$

$$20 \text{ ft. (from Table 2)} - (2 \times 1 \text{ ft.}) (1 \text{ ft. is the duct diameter}) = 18 \text{ ft}$$

If an 18 inch (1.5 ft.) diameter duct is to be used, the maximum length of perforated duct is 17 ft.:

$$20 \text{ ft.} - (2 \times 1.5 \text{ ft.}) = 17 \text{ ft.}$$

Table 1. Bin Capacity with/without cone.

Diameter (ft.)	Height (ft.)	Bin Capacity (bu)	Capacity due to Cone (bu)		Total Capacity (Bin+Cone),bu	
			45° cones	37° cones	45° cones	37° cones
15	8	1125	363	270	1488	1395
	13	1850	363	270	2213	2120
	16	2275	363	270	2638	2545
18	11	2250	610	450	2860	2700
	13	2650	610	450	3260	3100
	16	3275	610	450	3885	3725
	21	4300	610	450	4910	4750
21	13	3625	960	720	4585	4345
	16	4450	960	720	5410	5170
	24	6675	960	720	7635	7395
24	16	5825	1440	1080	7265	6905
	19	6900	1440	1080	8340	7980
	24	8725	1440	1080	10165	9805
	32	11625	1440	1080	13065	12705
27	19	8750	2060	1540	10810	10290
	24	11025	2060	1540	13085	12565
	32	14725	2060	1540	16785	16265
30	19	10775	2820	2120	13595	12895
	24	13625	2820	2120	16445	15745
	32	18175	2820	2120	20995	20295
33	24	16475	3850	2890	20325	19365
	27	18550	3850	2890	22400	21440
	32	21975	3850	2890	25825	24865
36	24	19625	4880	3660	24505	23285
	27	22075	4880	3660	26955	25735
	32	26150	4880	3660	31030	29810
	40	32700	4880	3660	37580	36360
42	27	30050	6315	4735	36365	34785
	32	35600	6315	4735	41915	40335
	40	44500	6315	4735	50815	49235
	48	53425	6315	4735	59740	58160
48	27	39250	7750	5810	47000	45060
	32	46500	7750	5810	54250	52310
	40	58150	7750	5810	65900	63960
	48	69775	7750	5810	77525	75585

Table 2. Duct Lengths for Cone-Shaped Foundations or Bottoms.

<i>Bin Diameter (ft.)</i>	<i>45° cones 1 in 1 slope Max. length of duct (ft.)</i>	<i>37° cones 3 in 4 slope Max. length of duct (ft.)</i>
14	9	8
15	9.75	9
18	12	10
21	14	12
24	16	14
27	18	16
30	20	18
36	24	21
42	28	25

Determining Air Velocity through the Grain

Table 3 and Table 4 are used to determine total air volume and the air velocity through the grain when the desired airflow rate is known. Table 3 is for 45 degree cones and Table 4 is for 37 degree cones. The choice of airflow rate is an important decision. Higher aeration airflow rates give greater management flexibility and allow the storage of grain with higher moisture content because the grain can be cooled and dried with natural air quicker. However, higher aeration airflow rates also require larger ducts, involve higher static pressures, and have greater power requirements. For a complete discussion of airflow rates, see BAE-1101.

Example: Using our sample bin (30 ft. diameter and 19 ft. height), suppose we wish to provide an airflow rate of 1/5 (0.2) CFM/bu. Table 3 gives a total air volume of about 2719 CFM and an air velocity through the grain of 3.85 fpm. If the cone bottom has a 37° cone, use Table 4.

Table 3. Total air volume and air velocity through the grain for grain bins with 45 degree cones.

<i>Diameter (ft.)</i>	<i>Height (ft.)</i>	<i>Total Capacity (Bin+ Cone), bu</i>	<i>Total Air Volume (cfm)</i>						<i>Air Velocity (fpm)</i>					
			<i>Air Flow Rate (cfm/bu)</i>						<i>Air Flow Rate (cfm/bu)</i>					
			<i>1/2</i>	<i>1/3</i>	<i>1/4</i>	<i>1/5</i>	<i>1/10</i>	<i>1/20</i>	<i>1/2</i>	<i>1/3</i>	<i>1/4</i>	<i>1/5</i>	<i>1/10</i>	<i>1/20</i>
15	8	1488	744	496	372	298	149	74	4.21	2.81	2.11	1.68	0.84	0.42
	13	2213	1107	738	553	443	221	111	6.26	4.18	3.13	2.51	1.25	0.63
	16	2638	1319	879	660	528	264	132	7.47	4.98	3.73	2.99	1.49	0.75
18	11	2860	1430	953	715	572	286	143	5.62	3.75	2.81	2.25	1.12	0.56
	13	3260	1630	1087	815	652	326	163	6.41	4.27	3.20	2.56	1.28	0.64
	16	3885	1943	1295	971	777	389	194	7.64	5.09	3.82	3.05	1.53	0.76
	21	4910	2455	1637	1228	982	491	246	9.65	6.43	4.83	3.86	1.93	0.97
21	13	4585	2293	1528	1146	917	459	229	6.62	4.41	3.31	2.65	1.32	0.66
	16	5410	2705	1803	1353	1082	541	271	7.81	5.21	3.91	3.13	1.56	0.78
	24	7635	3818	2545	1909	1527	764	382	11.03	7.35	5.51	4.41	2.21	1.10
24	16	7265	3633	2422	1816	1453	727	363	8.03	5.36	4.02	3.21	1.61	0.80
	19	8340	4170	2780	2085	1668	834	417	9.22	6.15	4.61	3.69	1.84	0.92
	24	10165	5083	3388	2541	2033	1017	508	11.24	7.49	5.62	4.50	2.25	1.12
	32	13065	6533	4355	3266	2613	1307	653	14.45	9.63	7.22	5.78	2.89	1.44
27	19	10810	5405	3603	2703	2162	1081	541	9.44	6.30	4.72	3.78	1.89	0.94
	24	13085	6543	4362	3271	2617	1309	654	11.43	7.62	5.72	4.57	2.29	1.14
	32	16785	8393	5595	4196	3357	1679	839	14.67	9.78	7.33	5.87	2.93	1.47
30	19	13595	6798	4532	3399	2719	1360	680	9.62	6.41	4.81	3.85	1.92	0.96
	24	16445	8223	5482	4111	3289	1645	822	11.64	7.76	5.82	4.66	2.33	1.16
	32	20995	10498	6998	5249	4199	2100	1050	14.86	9.91	7.43	5.94	2.97	1.49
33	24	20325	10163	6775	5081	4065	2033	1016	11.89	7.93	5.94	4.76	2.38	1.19
	27	22400	11200	7467	5600	4480	2240	1120	13.10	8.73	6.55	5.24	2.62	1.31
	32	25825	12913	8608	6456	5165	2583	1291	15.10	10.07	7.55	6.04	3.02	1.51
36	24	24505	12253	8168	6126	4901	2451	1225	12.04	8.03	6.02	4.82	2.41	1.20
	27	26955	13478	8985	6739	5391	2696	1348	13.25	8.83	6.62	5.30	2.65	1.32
	32	31030	15515	10343	7758	6206	3103	1552	15.25	10.17	7.63	6.10	3.05	1.53
	40	37580	18790	12527	9395	7516	3758	1879	18.47	12.31	9.23	7.39	3.69	1.85
42	27	36365	18183	12122	9091	7273	3637	1818	13.13	8.75	6.57	5.25	2.63	1.31
	32	41915	20958	13972	10479	8383	4192	2096	15.13	10.09	7.57	6.05	3.03	1.51
	40	50815	25408	16938	12704	10163	5082	2541	18.35	12.23	9.17	7.34	3.67	1.83
	48	59740	29870	19913	14935	11948	5974	2987	21.57	14.38	10.79	8.63	4.31	2.16
48	27	47000	23500	15667	11750	9400	4700	2350	12.99	8.66	6.50	5.20	2.60	1.30
	32	54250	27125	18083	13563	10850	5425	2713	15.00	10.00	7.50	6.00	3.00	1.50
	40	65900	32950	21967	16475	13180	6590	3295	18.22	12.15	9.11	7.29	3.64	1.82
	48	77525	38763	25842	19381	15505	7753	3876	21.43	14.29	10.72	8.57	4.29	2.14

Table 4. Total air volume and air velocity through the grain for grain bins with 37 degree cones.

Diameter (ft.)	Height (ft.)	Total Capacity (Bin+ Cone), bu	Total Air Volume (cfm)						Air Velocity (fpm)					
			Air Flow Rate (cfm/bu)						Air Flow Rate (cfm/bu)					
			1/2	1/3	1/4	1/5	1/10	1/20	1/2	1/3	1/4	1/5	1/10	1/20
15	8	1395	698	465	349	279	140	70	3.95	2.63	1.97	1.58	0.79	0.39
	13	2120	1060	707	530	424	212	106	6.00	4.00	3.00	2.40	1.20	0.60
	16	2545	1273	848	636	509	255	127	7.20	4.80	3.60	2.88	1.44	0.72
18	11	2700	1350	900	675	540	270	135	5.31	3.54	2.65	2.12	1.06	0.53
	13	3100	1550	1033	775	620	310	155	6.09	4.06	3.05	2.44	1.22	0.61
	16	3725	1863	1242	931	745	373	186	7.32	4.88	3.66	2.93	1.46	0.73
	21	4750	2375	1583	1188	950	475	238	9.34	6.23	4.67	3.74	1.87	0.93
21	13	4345	2173	1448	1086	869	435	217	6.28	4.18	3.14	2.51	1.26	0.63
	16	5170	2585	1723	1293	1034	517	259	7.47	4.98	3.73	2.99	1.49	0.75
	24	7395	3698	2465	1849	1479	740	370	10.68	7.12	5.34	4.27	2.14	1.07
24	16	6905	3453	2302	1726	1381	691	345	7.64	5.09	3.82	3.05	1.53	0.76
	19	7980	3990	2660	1995	1596	798	399	8.82	5.88	4.41	3.53	1.76	0.88
	24	9805	4903	3268	2451	1961	981	490	10.84	7.23	5.42	4.34	2.17	1.08
	32	12705	6353	4235	3176	2541	1271	635	14.05	9.37	7.02	5.62	2.81	1.40
27	19	10290	5145	3430	2573	2058	1029	515	8.99	5.99	4.50	3.60	1.80	0.90
	24	12565	6283	4188	3141	2513	1257	628	10.98	7.32	5.49	4.39	2.20	1.10
	32	16265	8133	5422	4066	3253	1627	813	14.21	9.47	7.11	5.68	2.84	1.42
30	19	12895	6448	4298	3224	2579	1290	645	9.13	6.08	4.56	3.65	1.83	0.91
	24	15745	7873	5248	3936	3149	1575	787	11.14	7.43	5.57	4.46	2.23	1.11
	32	20295	10148	6765	5074	4059	2030	1015	14.36	9.58	7.18	5.75	2.87	1.44
33	24	19365	9683	6455	4841	3873	1937	968	11.33	7.55	5.66	4.53	2.27	1.13
	27	21440	10720	7147	5360	4288	2144	1072	12.54	8.36	6.27	5.02	2.51	1.25
	32	24865	12433	8288	6216	4973	2487	1243	14.54	9.70	7.27	5.82	2.91	1.45
36	24	23285	11643	7762	5821	4657	2329	1164	11.44	7.63	5.72	4.58	2.29	1.14
	27	25735	12868	8578	6434	5147	2574	1287	12.65	8.43	6.32	5.06	2.53	1.26
	32	29810	14905	9937	7453	5962	2981	1491	14.65	9.77	7.33	5.86	2.93	1.47
	40	36360	18180	12120	9090	7272	3636	1818	17.87	11.91	8.93	7.15	3.57	1.79
42	27	34785	17393	11595	8696	6957	3479	1739	12.56	8.37	6.28	5.02	2.51	1.26
	32	40335	20168	13445	10084	8067	4034	2017	14.56	9.71	7.28	5.83	2.91	1.46
	40	49235	24618	16412	12309	9847	4924	2462	17.78	11.85	8.89	7.11	3.56	1.78
	48	58160	29080	19387	14540	11632	5816	2908	21.00	14.00	10.50	8.40	4.20	2.10
48	27	45060	22530	15020	11265	9012	4506	2253	12.46	8.30	6.23	4.98	2.49	1.25
	32	52310	26155	17437	13078	10462	5231	2616	14.46	9.64	7.23	5.78	2.89	1.45
	40	63960	31980	21320	15990	12792	6396	3198	17.68	11.79	8.84	7.07	3.54	1.77
	48	75585	37793	25195	18896	15117	7559	3779	20.90	13.93	10.45	8.36	4.18	2.09

Determining Operating Static Pressure Due to Grain Depth

Tables 5, 6, 7, 8, and 9 can be used to determine the static pressure due to grain depth when the grain depth or bin sidewall height and the air flow rate through the grain are known. It is assumed the bin will be filled to the eaves and the top surface will be leveled, making grain depth and bin sidewall height equal. Table 5 is used when shelled corn is the grain to be aerated, Table 6 is used for barley and oats, Table 7 for soybeans and confectionary sunflowers, Table 8 for oil-type sunflowers and Table 9 for wheat and sorghum. The static pressure of canola is two to three times the static pressure of wheat. Therefore, if an existing aeration system designed for wheat is used for canola, check the velocity and pressure ratings of the system to ensure adequate airflow. Fact Sheet BAE-1110, "Storing Oklahoma Winter Canola," covers the methods for storing Oklahoma winter canola. When the system will be used for more than one grain, design for the grain that gives the highest expected static pressure.

Example: To design the system for our sample bin (19 ft. height) to store either corn or soybeans, consider both Table 5 and Table 7. Since the tables do not give data for 0.2 cfm/bu airflow rates, use the next higher airflow given. In this case, we would use 0.25 cfm/bu. The tables do not give data for 19 ft. height either, so we would calculate the static pressure that would be halfway between the pressures shown for 18 ft and 20 ft heights.

For corn (Table 5): at 18 ft grain depth, pressure = 0.5 in. and at 20 ft., pressure = 0.7 in. Therefore, at 19 ft. grain depth, the pressure will be 0.6 in. or halfway between 0.5 and 0.7 in.

For soybeans (Table 7): at 18 ft grain depth, pressure = 0.4 in. and at 20 ft., pressure = 0.6 in. Therefore, at 19 ft. grain depth, the pressure will be 0.5 in.

Since we would like to design our system to handle either crop, we must design for the greater pressure requirements. In this case, it would be corn and we would use 0.6 in. for our pressure requirement due to grain depth.

Table 5. Expected Static Pressure for shelled corn.

Values in the table have been multiplied by 1.5 to account for fines and packing in the bin. (If corn is stirred, which tends to decrease airflow resistance, divide table values by 1.5.)

Grain depth (ft)	Airflow (cfm/bu)								
	0.05	0.1	0.25	0.5	0.75	1	1.25	1.5	2
	<i>Expected static pressure (inches of water)</i>								
2	0.1	0.1	0.1	0.1	0.1	0.1	0.1	0.1	0.1
4	0.1	0.1	0.1	0.1	0.1	0.1	0.1	0.2	0.2
6	0.1	0.1	0.1	0.1	0.2	0.3	0.3	0.4	0.6
8	0.1	0.1	0.1	0.2	0.3	0.5	0.6	0.8	1.2
10	0.1	0.1	0.2	0.3	0.5	0.8	1.1	1.4	2
12	0.1	0.1	0.2	0.5	0.8	1.2	1.6	2.1	3.2
14	0.1	0.1	0.3	0.7	1.2	1.7	2.3	3	4.6
16	0.1	0.1	0.4	0.9	1.6	2.4	3.2	4.2	6.4
18	0.1	0.2	0.5	1.2	2.1	3.1	4.3	5.6	8.7
20	0.1	0.2	0.7	1.6	2.7	4	5.6	7.3	11.3
25	0.2	0.4	1.1	2.6	4.6	7	9.7	12.8	19.9
30	0.3	0.5	1.6	4.1	7.2	11	15.3	20.3	31.9
40	0.5	1	3.1	8.1	14.6	22.6	31.9	42.5	*
50	0.7	1.6	5.3	14	25.6	39.9	*	*	*

* Static pressure is excessive--greater than 50 in. water.

Table 6. Expected Static Pressure for barley and oats.

Values in the table have been multiplied by 1.5 to account for fines and packing in the bin.

Grain depth (ft)	Airflow (cfm/bu)								
	0.05	0.1	0.25	0.5	0.75	1	1.25	1.5	2
	<i>Expected static pressure (inches of water)</i>								
2	0.1	0.1	0.1	0.1	0.1	0.1	0.1	0.1	0.1
4	0.1	0.1	0.1	0.1	0.2	0.2	0.3	0.3	0.5
6	0.1	0.1	0.1	0.2	0.4	0.5	0.7	0.8	1.1
8	0.1	0.1	0.2	0.4	0.7	0.9	1.2	1.5	2.1
10	0.1	0.1	0.3	0.7	1.1	1.5	2	2.5	3.6
12	0.1	0.2	0.5	1	1.6	2.3	3	3.7	5.4
14	0.1	0.3	0.7	1.4	2.2	3.2	4.2	5.3	7.8
16	0.2	0.3	0.9	1.9	3	4.3	5.7	7.2	10.6
18	0.2	0.4	1.1	2.4	3.9	5.6	7.5	9.5	14.1
20	0.3	0.5	1.4	3	4.9	7.1	9.5	12.2	18.1
15	0.4	0.8	2.2	4.9	8.2	11.9	16.1	20.7	31.1
30	0.6	1.2	3.2	7.4	12.4	18.3	24.8	32.1	48.7
40	1	2.1	6	14.2	24.4	36.2	49.8	*	*
50	1.6	3.4	9.9	23.8	41.4	*	*	*	*

* Static pressure is excessive--greater than 50 in. water.

Determining Static Pressure Due to Duct and Cone

Pressure requirements are also increased due to air traveling through the air ducts. To find these pressure requirements, the surface area of the ductwork must be known. Table 10 gives the duct surface area given the duct diameter and the duct length. Tables 11 and 12 use the surface area from Table 10 and the air-flow volume calculated earlier to determine the expected static pressure for the duct system and for the airflow through the cone part of the bin. This pressure added to the pressure for the grain depth is the design pressure used to select the aeration fans.

Example:

- For the sample bin using 12 in. duct diameter and 18 ft. duct length, the duct surface area is 45 sq. ft. (Table 10).
- Using Table 11 for corn or soybeans, 45 sq. ft. duct surface area, and 2719 cfm (rounded up to 3000 cfm) air volume, the static pressure due to the duct system and the cone is 3.8 in. (use pressure half way between 40 sq. ft. and 50 sq. ft. since there is not data for 45 sq. ft)
- For the total pressure requirement, add the pressure due to grain depth and the pressure through the cone and duct system: 0.5 in. + 3.8 in. = 4.3 in.
When the bin will be used to store more than one grain,

Table 7. Expected Static Pressure for soybeans and confectionary sunflowers.

Values in the table have been multiplied by 1.5 to account for fines and packing in the bin.

Grain depth (ft)	Airflow (cfm/bu)								
	0.05	0.1	0.25	0.5	0.75	1	1.25	1.5	2
	<i>Expected static pressure (inches of water)</i>								
2	0.1	0.1	0.1	0.1	0.1	0.1	0.1	0.1	0.1
4	0.1	0.1	0.1	0.1	0.1	0.1	0.1	0.1	0.2
6	0.1	0.1	0.1	0.1	0.2	0.2	0.3	0.3	0.5
8	0.1	0.1	0.1	0.2	0.3	0.4	0.5	0.6	0.9
10	0.1	0.1	0.1	0.3	0.4	0.6	0.8	1	1.5
12	0.1	0.1	0.2	0.4	0.7	0.9	1.2	1.6	2.3
14	0.1	0.1	0.3	0.6	0.9	1.3	1.7	2.2	3.3
16	0.1	0.1	0.3	0.8	1.2	1.8	2.4	3	4.5
18	0.1	0.2	0.4	1	1.6	2.3	3.1	4	6
20	0.1	0.2	0.6	1.2	2	3	4	5.1	7.7
25	0.2	0.3	0.9	2	3.4	5	6.8	8.8	13.4
30	0.2	0.5	1.3	3.1	5.2	7.7	10.6	13.7	21
40	0.4	0.9	2.5	5.9	10.3	15.4	21.4	28	43.4
50	0.6	1.4	4.1	10	17.6	26.7	37.2	49.1	*

* Static pressure is excessive--greater than 50 in. water.

Table 8. Expected Static Pressure for oil-type sunflowers.

Values in the table have been multiplied by 1.5 to account for fines and packing in the bin.

Grain depth (ft)	Airflow (cfm/bu)								
	0.05	0.1	0.25	0.5	0.75	1	1.25	1.5	2
	<i>Expected static pressure (inches of water)</i>								
2	0.1	0.1	0.1	0.1	0.1	0.1	0.1	0.1	0.1
4	0.1	0.1	0.1	0.1	0.1	0.2	0.2	0.2	0.3
6	0.1	0.1	0.1	0.2	0.3	0.4	0.5	0.6	0.9
8	0.1	0.1	0.1	0.3	0.5	0.7	0.9	1.1	1.7
10	0.1	0.1	0.2	0.5	0.8	1.1	1.5	1.9	2.8
12	0.1	0.1	0.3	0.7	1.2	1.7	2.3	2.9	4.4
14	0.1	0.2	0.5	1	1.7	2.4	3.3	4.2	6.4
16	0.1	0.2	0.6	1.4	2.3	3.3	4.5	5.8	8.8
18	0.1	0.3	0.8	1.8	3	4.4	6	7.8	11.8
20	0.2	0.3	1	2.3	3.8	5.6	7.7	10	15.3
25	0.3	0.6	1.6	3.7	6.5	9.7	13.3	17.4	26.9
30	0.4	0.8	2.4	5.7	10	15.1	20.9	27.5	42.7
40	0.7	1.5	4.5	11.3	20.1	30.7	43	*	*
50	1.1	2.4	7.5	19.3	34.8	*	*	*	*

* Static pressure is excessive--greater than 50 in. water.

Table 9. Expected Static Pressure for wheat and sorghum.

Values in the table have been multiplied by 1.3 for wheat and 1.5 for sorghum to account for fines and packing in the bin.

Grain depth (ft)	Airflow (cfm/bu)								
	0.05	0.1	0.25	0.5	0.75	1	1.25	1.5	2
	<i>Expected static pressure (inches of water)</i>								
2	0.1	0.1	0.1	0.1	0.1	0.1	0.1	0.1	0.2
4	0.1	0.1	0.1	0.2	0.3	0.3	0.4	0.5	0.7
6	0.1	0.1	0.2	0.4	0.6	0.8	1	1.2	1.7
8	0.1	0.1	0.3	0.7	1.1	1.5	1.9	2.3	3.2
10	0.1	0.2	0.5	1.1	1.7	2.3	3	3.7	5.3
12	0.1	0.3	0.8	1.6	2.5	3.4	4.5	5.6	7.9
14	0.2	0.4	1	2.2	3.4	4.8	6.3	7.8	11.3
16	0.3	0.5	1.4	2.9	4.6	6.4	8.4	10.6	15.3
18	0.3	0.7	1.7	3.7	5.9	8.3	11	13.8	20
20	0.4	0.8	2.2	4.7	7.5	10.5	13.9	17.6	25.6
25	0.6	1.3	3.4	7.5	12.2	17.4	23.1	29.4	43.3
30	0.9	1.9	5.1	11.2	18.3	26.3	35.3	45	*
40	1.7	3.4	9.3	21.1	35.1	*	*	*	*
50	2.6	5.4	15	34.8	*	*	*	*	*

* Static pressure is excessive--greater than 50 in. water.

Table 10. Duct Surface Area.

Duct Diameter (inches)	Duct Length (ft)	Duct Surface Area (Sq. ft.)
6	10	13
	15	19
	20	25
	25	31
	30	38
	35	44
10	10	21
	15	31
	20	42
	25	52
	30	63
	35	73
12	10	25
	15	38
	18	45
	20	50
	25	63
	30	75
	35	88
15	10	31
	20	63
	25	79
	30	94
	35	110
18	10	38
	15	57
	20	75
	25	94
	30	113
	35	132
	20	10
15		63
20		84
25		105
30		126
35		147
24	10	50
	15	75
	20	100
	25	126
	30	151
	35	176
	30	10
15		94
20		126
25		157
30		188
35		220
36	10	75
	15	113
	20	151
	25	188
	30	226
	35	264
	40	10
15		126
20		167
25		209
30		251
35		293

the grain which produces the highest static pressure should be used for design purposes. The static pressure of canola is two to three times that of wheat.

The static pressure due to duct and cone can be reduced by choosing a larger diameter duct. Table 13 compares the results obtained for a 12-inch diameter duct with those obtained for 18- and 21-inch diameter ducts.

Selecting Fans

Fans are selected from the manufacturer's rating curves or tables to deliver the required air volume when operating against the expected static pressure. Axial fans (propeller-type) are commonly used for aeration since they produce high air volumes at low static pressures. However, air volumes delivered by axial fans fall off rapidly as static pressures increase through the 3.5 to 5.0 inch range. Above this range, centrifugal fans with backward-inclined blades must be used. In special designs, centrifugal fans will operate efficiently at static pressures of 20 inches or more.

Centrifugal fans operate with less noise than axial fans and should be used whenever fan noise may be a nuisance to neighbors. Centrifugal fans of 3 Hp or less cost two to three times as much as axial fans of the same Hp rating. Above 5 Hp, centrifugal fans cost 1.5 to 2 times as much as axial fans of the same Hp rating.

The lowest priced fan which will deliver the required air volume when operating at the expected static pressure is, of course, the most economical fan to buy. However, the most economical fan to operate is the fan with the lowest power consumption, measured in watts, while delivering the required air volume at the expected static pressure. Nominal horsepower rating is not a good measure of power consumption.

While final fan selection must be made from manufacturer's data, an estimate of the power requirement may be helpful for planning purposes. Equation 1 is used to estimate the power requirement, assuming a fan efficiency of 50 percent.

$$hp = \frac{(cfm \times P_s)}{(63.46 \times efficiency)} \quad \text{equation 1}$$

where:

cfm = airflow in cfm

P_s = static pressure in inches of water

efficiency = fan efficiency (%)

Example: Our example calls for an air volume of 2719 CFM. If the operating pressure is 4.3 inches, the power requirement is about 3.68 Hp (select a 5 HP motor). Table 13 also compares the power requirements resulting from the use of a 12-inch diameter duct with those resulting from the use of 18- and 24-inch diameter ducts.

When selecting fans, consult the data from several manufacturers. Tables 14 and 15 present typical performance data for axial and centrifugal fans, respectively. One manufacturer's 5 Hp fan may be well matched to your needs while another's 5 Hp fan may not. Fan performance data should be certified in accordance with standard test codes adopted by Air Moving and Conditioning Association, Incorporated and bear the AMCA seal.

Table 11. Expected static pressure due to duct and cone for corn or soybeans.

Duct Surface Area (Sq. ft.)	Total Air Volume (CFM)												
	100	500	1000	2000	3000	4000	5000	6000	7000	8000	10000	20000	30000
<i>Expected Static Pressure (inches of water)</i>													
10	0.26	2.5	7.5	*	*	*	*	*	*	*	*	*	*
15	0.15	1.4	3.9	10	*	*	*	*	*	*	*	*	*
20	0.1	0.91	2.5	6	*	*	*	*	*	*	*	*	*
30	**	0.54	1.4	3.7	6.5	*	*	*	*	*	*	*	*
40	**	0.35	0.92	2.5	4.4	6.4	8.5	*	*	*	*	*	*
50	**	0.26	0.7	1.75	3.2	5	6.8	8.5	*	*	*	*	*
60	**	0.21	0.55	1.45	2.45	3.8	5.1	6.8	8	*	*	*	*
80	**	0.14	0.27	0.94	1.7	2.5	3.35	4.45	5.4	6.5	8.6	*	*
100	**	0.1	0.26	0.69	1.3	1.8	2.5	3.3	3.9	4.7	6.3	*	*
150	**	**	0.16	0.39	0.7	1.1	1.45	1.9	2.3	2.7	3.6	*	*
200	**	**	0.12	0.27	0.46	0.65	0.75	1.3	1.5	1.8	2.6	6.5	*
300	**	**	**	0.15	0.27	0.39	0.5	0.7	0.85	1.05	1.49	3.75	6.8

** Static pressure is less than 0.1 in. water

*Static pressure is excessive--greater than 10 in. water

Table 12. Expected static pressure due to duct and cone for wheat, grain sorghum, oats, barley, or rye.

Duct Surface Area (Sq. ft.)	Total Air Volume (CFM)												
	100	500	1000	2000	3000	4000	5000	6000	7000	8000	10000	20000	30000
<i>Expected Static Pressure (inches of water)</i>													
10	0.8	5.5	13	*	*	*	*	*	*	*	*	*	*
15	0.49	3.4	7.9	*	*	*	*	*	*	*	*	*	*
20	0.35	2.4	5.5	12	*	*	*	*	*	*	*	*	*
30	**	1.45	3.4	7.8	12.8	*	*	*	*	*	*	*	*
40	**	1	2.4	5.5	9	12.5	*	*	*	*	*	*	*
50	**	0.8	1.85	4.2	6.8	10	13	*	*	*	*	*	*
60	**	0.65	1.5	3.45	5.4	7.9	10.1	13	15	*	*	*	*
80	**	0.45	0.8	2.4	3.8	5.5	7	9	10.8	12.5	*	*	*
100	**	0.35	0.79	1.8	2.9	4.3	5.5	7	8.1	9.5	12.2	*	*
150	**	**	0.5	1.1	1.8	2.55	3.4	4.4	4.9	5.8	7.5	*	*
200	**	**	0.37	0.8	1.3	1.8	2.4	3	3.5	4.2	5.6	12.9	*
300	**	**	**	0.5	0.84	0.12	1.5	1.85	2.2	2.6	3.45	7.9	13

** Static pressure is less than 0.3 in. water

*Static pressure is excessive--greater than 15 in. water

Table 13. Static Pressures and Power Requirements resulting from three duct diameters in the example.

	Duct Diameter (inches)		
	12	18	24
Maximum length of Perforated Duct (ft)	18	17	16
Static Pressure due to Duct and Cone (inches of water) For Corn or Soybeans	3.8	2	1.5
Total Static Pressure (inches of water) For Corn or Soybeans	4.3	2.6	2.1
Power Required assuming 50% efficiency (Hp) For Corn or Soybeans	3.7	2.2	1.8

Further Examples

Example 1: An aeration system is desired for a 24 feet diameter bin with 16 feet sidewalls and 37° cone shaped foundation which will be used to store wheat. An airflow rate of 1/4 (0.25) CFM/bu is desired.

- a) Bin capacity is 6905 bu (Table 1). Airflow volume: 6905 bu x 0.25 CFM/bu = 1726 CFM (also in Table 4).
- b) From Table 2, maximum duct length is 14 feet.
- c) Air velocity through the grain is 3.82 fpm (Table 4). The static pressure due to the 16 feet grain depth is 1.4 inches (Table 9).

- d) Maximum perforated duct if an 18 in. dia. duct is selected: 14 ft – (2 x 1.5 ft) = 11 ft.
- e) Duct surface area: The duct surface area of 10ft and 15ft duct is known (Table 10). Estimate for 11ft duct length using interpolation: $38 + ((11-10) * (57-38)) / (15-10) = 38 + 3.8 = 42$ sq. ft. (Table 10).
- f) Static Pressure due to cone and duct, as static pressure for 1726 cfm and 42 sq ft area is not given directly in Table 12 therefore we calculate the static pressure for 2000 cfm and 42 sq ft by interpolation: $5.5 + ((42-40) * (4.2-5.5)) / ((50-40)) = 5.24$ in. of water (Table 12).
- g) Total static pressure: 5.24 + 1.4 in. = 6.64.
- h) Approx. HP: $hp = (1726 * 6.64) / (63.46 * 50) = 3.61$ HP (equation 1)
- i) Choose a 4 HP fan.

Example 2: Suppose a producer wishes to provide 1/2 (0.5) CFM/bu. for quick cooling of damp corn during harvest. The bin is 27 feet in diameter, has 24 feet sidewalls and a 45° cone shaped foundation.

- a) Bin capacity is 13085 bu (Table 1). Airflow volume: 13085 bu x 0.50 CFM/bu = 6543 CFM (also in Table 3).
- b) From Table 2, maximum duct length is 18 feet.
- c) Air velocity through the grain is 11.43 fpm (Table 3). The static pressure due to the 24 feet grain depth is 2.4 inches (Table 5).
- d) Maximum perforated duct: If 30 in duct is selected, round up to 3 feet, 18 ft – (2 x 3 ft) = 13 ft.
- e) Duct surface area, using interpolation and Table 10: $63 + ((13-10) * (94-63)) / (15-10) = 63 + 18.6 = 81.6$ Sq. ft. = 82 Sq. ft. (Table 10).

Table 14. Typical Performance Data for Axial Fans`.

HP	RPM	Static Pressure (Inches of water)					
		0.5	1.0	1.5	2.0	3.0	4.0
CFM							
1	3450	2880	2635	2360	1935	810	455
3	3450	7000	6400	5700	5200	3700	2200
5	3450	9700	9100	8600	8000	6500	4600
7.5	3450	12800	12300	11600	11000	9800	7400

*This table is abbreviated. Intermediate static pressures and a much larger range of CFM values are normally shown

Table 15. Typical Performance Data for Centrifugal Fan`.

CFM	Static Pressure (inches of water)													
	2		4		6		8		10		12		14	
	RPM	HP	RPM	HP	RPM	HP	RPM	HP	RPM	HP	RPM	HP	RPM	HP
1520	1364	1.15	1753	1.96	2064	2.77	2332	3.6	2574	4.47	2794	5.37	3000	6.3
2026	1527	1.81	1894	2.89	2190	3.94	2446	4.99	2679	6.05	2891	7.14	3090	8.25
2532	1708	2.72	2050	4.07	2334	5.4	2584	6.71	2805	8.01	3010	9.3	3204	10.6
3039	1906	3.93	2221	5.5	2490	7.15	2730	8.75	2946	10.3	3145	11.8	3333	13.4

*This table is abbreviated. Intermediate static pressures and a much larger range of CFM values are normally shown

- f) Pressure due to cone and duct, as static pressure for 6543 cfm and 82 sq ft area is not given directly in Table 11 therefore we calculate the static pressure for 7000 cfm and 75.4 sq ft by interpolation:

$$5.4 + ((82-80) \times (3.9-5.4) / (100-80)) = 5.25 \text{ (Table 11)}$$

- g) Total static pressure: $5.25 + 2.4 \text{ in.} = 7.65$.
h) Approx. HP : $hp = (6543 \times 7.65) / (63.46 \times 50) = 15.8 \text{ HP}$ (equation 1).
i) Choose a 16 HP fan.

Other Considerations

Aeration systems for cone-bottom bins must operate as pressure systems-blowing air upward through the grain. For

more information about pressure and suction systems, see BAE-1101.

There must be sufficient roof openings to allow the air to escape. The required air escape area, in square feet, is determined by dividing the total air volume by 1,500 fpm. If the bin roof is mounted off the sidewall, the slot under the eaves serves as air escape area. When additional area is required, roof vents should be installed until the air escape area requirement is met.

When aeration systems are operating, the unloading auger tube should be sealed to prevent the escape of air.

Smooth transitions should be used to connect fan outlets with duct inlets. Sudden reductions or increases in duct diameters should be avoided.

The Oklahoma Cooperative Extension Service

Bringing the University to You!

The Cooperative Extension Service is the largest, most successful informal educational organization in the world. It is a nationwide system funded and guided by a partnership of federal, state, and local governments that delivers information to help people help themselves through the land-grant university system.

Extension carries out programs in the broad categories of agriculture, natural resources and environment; family and consumer sciences; 4-H and other youth; and community resource development. Extension staff members live and work among the people they serve to help stimulate and educate Americans to plan ahead and cope with their problems.

Some characteristics of the Cooperative Extension system are:

- The federal, state, and local governments cooperatively share in its financial support and program direction.
- It is administered by the land-grant university as designated by the state legislature through an Extension director.
- Extension programs are nonpolitical, objective, and research-based information.
- It provides practical, problem-oriented education for people of all ages. It is designated to take the knowledge of the university to those persons who do not or cannot participate in the formal classroom instruction of the university.
- It utilizes research from university, government, and other sources to help people make their own decisions.
- More than a million volunteers help multiply the impact of the Extension professional staff.
- It dispenses no funds to the public.
- It is not a regulatory agency, but it does inform people of regulations and of their options in meeting them.
- Local programs are developed and carried out in full recognition of national problems and goals.
- The Extension staff educates people through personal contacts, meetings, demonstrations, and the mass media.
- Extension has the built-in flexibility to adjust its programs and subject matter to meet new needs. Activities shift from year to year as citizen groups and Extension workers close to the problems advise changes.

Oklahoma State University, in compliance with Title VI and VII of the Civil Rights Act of 1964, Executive Order 11246 as amended, Title IX of the Education Amendments of 1972, Americans with Disabilities Act of 1990, and other federal laws and regulations, does not discriminate on the basis of race, color, national origin, gender, age, religion, disability, or status as a veteran in any of its policies, practices, or procedures. This includes but is not limited to admissions, employment, financial aid, and educational services.

Issued in furtherance of Cooperative Extension work, acts of May 8 and June 30, 1914, in cooperation with the U.S. Department of Agriculture, Robert E. Whitson, Director of Cooperative Extension Service, Oklahoma State University, Stillwater, Oklahoma. This publication is printed and issued by Oklahoma State University as authorized by the Vice President, Dean, and Director of the Division of Agricultural Sciences and Natural Resources and has been prepared and distributed at a cost of 64 cents per copy. 0809 GH.